



Sicom2 HF and RV

The safe and comfortable seat





The latest version of this instruction manual is available from the manufacturer or can be downloaded directly from our homepage using the QR code provided.

Before using your new Sicom2 HF/RV seat for the first time, please read this manual carefully and observe the guidelines and notes.

We wish you much pleasure with your new Sicom2 HF/RV seat and may you always have a good trip!

Your Schnierle team

Content

1. Guideline and introduction	3
1.1. Intended use.....	3
1.2. Product specific data	3
1.3. Introduction/notes	3
1.4. Use of the instruction manual.....	3
2. Putting into operation, control, service/maintenance and care.....	4
2.1. Putting into operation	4
2.2. Checks	5
2.3. Service und maintenance	5
2.4. Care	5
2.4.1. Belt/restraint system	5
2.4.2. Seat.....	5
3. Operation of the Sicom2 HF/RV seat.....	6
3.1. Head restraints	6
3.2. Safety belts	6
3.3. Child safety systems – ISOFIX & Top-Tether (optional)	7
3.3.1. ISOFIX attachment.....	7
3.3.2. Top-Tether attachment.....	7
3.4. Arm rests (optional)	8
3.5. Adjustment of the backrest (optional).....	8
4. Product information and dimensions	9
4.1. Product description.....	9
4.2. Varianten/Ausführungen/Optionen	9
4.3. Scope of application	9
4.4. Dimensions	10
4.5. Load limits.....	10
5. Notes on disposal	10



1. Guideline and introduction

1.1. Intended use

- The intended use for your seat is sitting while driving for the purpose of passenger transport. Of course, the seat can also be used as such when the vehicle is stationary.
- All use cases varying from the intended use can cause damages and functional errors, which can affect safe use of your seat.
- Not complying the descriptions contained in this instruction manual may adversely affect your warranty. Hermann Schnierle GmbH does not accept any warranty or liability for resulting damage in the event of improper assembly, use and repair.
- Any change to the standard condition (e.g. by retrofitting of non-original retrofit and spare parts from Hermann Schnierle GmbH) may invalidate the tested and approved condition. Functions may be impaired, endangering your safety. For this reason every structural modification to the seat is strictly prohibited unless this has been expressly approved in writing in advance by Hermann Schnierle GmbH.

Caution

- Note: Schnierle seating systems may only be used in combination with the matching Schnierle leg and floor systems!
- Do not climb on the seat, this may damage your seat.
- Do not use the seat for transporting loads.

1.2. Product specific data

- Please refer to your order and the delivery note for the scope of delivery according to the variant you have selected and ordered, see also 4.2. ➡ P. 10

1.3. Introduction/notes

This instruction manual provides you with all information you need for safe and efficient use of your seat.

You are obliged to comply with the applicable laws and regulations of the country in which you are located. These may differ from the information in this instruction manual.

The operating instructions of the vehicle and body manufacturers must also be observed.

- The latest version of this instruction manual is available from the manufacturer or can be downloaded directly from our homepa-ge using the QR code provided.
- The instruction manual must be read in full **before** putting into operation.
- Always keep the instruction manual and the QR code provided within easy reach in case of need, they should be carried in the vehicle and be accessible to the driver at all times.
- If the seat is passed on to a third party, the instruction manual must be passed on too.
- We reserve the right to make changes due to further developments that serve technical progress and the resulting deviations from the standard seat.

1.4. Use of the instruction manual

- In this instruction manual all options and features available for this model are described. Some descriptions may not apply due to the model variant selected.
- The table of contents at the beginning of this instruction manual helps you to orientate yourself quickly.
- Directional indications such as left/right or front/rear always refer to the direction of travel.



• Danger, warning and attention

Danger	Warning	Caution
Texts marked with Danger indicate a risk of serious injury. Failure to comply this warning may endanger life.	Texts marked with Warning indicate risks of accident and injury. Failure to observe the descriptions may result in injury.	Texts marked with Caution indicate possible damage to your Schnierle product. Failure to follow the description may result in damage to the product.

• Symbols

	Warning - relevant to safety
	Top-Tether fixing lugs
	Page references (Means see page...)

2. Putting into operation, control, service/maintenance and care

- Regular inspections, maintenances and care are important and necessary for the operational and road safety as well as the value retention of your seat.
- When installing or removing the seat, it is essential to follow the vehicles manufacturer's instructions.
- The seat should only be installed, maintained and repaired by specialist staff. Any country-specific regulations and installation instructions of the vehicle manufacturer must be taken into account. The country-specific installation regulations can be obtained from the body or vehicle manufacturer.
- Make sure that no liquids get into the interior of the vehicle, the seat is not water proof and should therefore be protected from splash water.

2.1. Putting into operation

- Improper installation may result in injuries or material damages and the function of the seat or attached parts cannot be guaranteed.
- Remove the packaging material (cardboard boxes, foils, etc.) completely before using the seat and dispose it properly.

Danger
<ul style="list-style-type: none"> ➤ To avoid the risk of accidents, check that all functions of your seat are in place before putting it into operation. ➤ The seat, in particular safety-relevant assemblies (e.g. safety belts, belt buckle, head restraints) should also be checked for damage, strength and function before driving (see also 2.2. Checks).



2.2. Checks

 **Warning**

- Regularly check the restraint system (Recommended: Before each journey).
- Check that the seat belt is not cut, damaged or frayed and has not been contaminated with dirt, oil or chemicals.
- Check that the metal and plastic parts are not worn, broken or damaged.
- Check all fitting parts like screws, nuts etc. for tightness.
- Check the anchorages of the shoulder straps for correct position and the shoulder straps themselves for correct function. When putting on the seat belt, a clicking sound must be heard (engaged in the belt buckle).
- To avoid the risk for accidents, it must be checked if all adjustment devices are engaged before operating the vehicle.

2.3. Service und maintenance

- The maintenance of your seat with restraint system must be carried out by an authorised specialist company (e.g. body manufacturer) at the same time as the regular vehicle maintenance, but after 1 year at the latest, unless otherwise described.
- If defects are found during the inspections (e.g. screw connection loose, parts damaged, belt frayed...), these must be repaired immediately and exclusively by competent persons (e.g. authorised repair shop of the body manufacturer).
- After an accident, the affected restraint belts must be replaced. Furthermore the seat, the seat attachment and the seat components have to inspected by qualified specialist staff after an accident.
- The restraint belts and the belt buckle integrated in the seat are replaceable. Replacment is only possible after prior approval by Hermann Schnierle GmbH (by trained and qualified personnel).
- Modification or retrofitting work on the seats from Hermann Schnierle GmbH may only be carried out by authorised specialist repair shops, trained personnel or after approval by Hermann Schnierle GmbH, taking into account the applicable work instructions and country-specific regulations.

In case of improper installation, there is a risk of injury or material damage and the function of the seat or the attached components cannot be guaranteed.

2.4. Care

General: Dirt can impair the function of your restraint system and the seat, therefore keep both clean and avoid contaminations if possible!

2.4.1. Belt/restraint system

- Clean the belt straps with mild, neutral soap and water when necessary.
- After cleaning, pull out the webbing completely. Note that the belt may only be retracted after it is completely dry.

2.4.2. Seat

- Regular contamination should be cleaned with a vacuum cleaner. In the case of heavier contamination, these can be cleaned using commercially available upholstery, leather or plastic cleaners. The compatibility should be tested prior on concealed, smaller surfaces. Please follow the instructions of the cleaning agent manufacturer.



- Upholstery does not have to be detached and removed from the seat frame for care. Furthermore, the seat must not be cleaned of dirt with unsuitable cleaners (e.g. high-pressure cleaners etc.).
- When cleaning the upholstered surfaces, avoid soaking the upholstery.

3. Operation of the Sicom2 HF/RV seat

3.1. Head restraints

Your Sicom2 HF/RV has a head restraint integrated into the seat.

3.2. Safety belts

 Danger
➤ Fasten seat belts before every journey. People, who are not wearing seat belts endanger themselves and other passengers in the event of an accident.

- The seat belts are designed for only one person at a time.
- Child safety systems see 3.3. ➡ P. 7
- Check all components of the safety belt system for damages and proper function.
- Loose or bulky clothing will impair the tight fit of the seat belt. Do not place objects such as e.g. purses or mobile phones between the seat belt and the body.

Safety belt:



To release the belt buckle, press the red button.

Pull the belt webbing out of the retractor, place it untwisted over the body and insert the buckle tongue into the buckle until you hear it click into place. Make sure that the belt is tight against the body while driving. The belt buckle may only be released by pressing the the seat belt buckle after the vehicle has come to a complete standstill and with the engine switched off.

 Warning
➤ Objects and loads must not be secured by the belt system. This can cause injuries by objects flying around and damage your belt system.
➤ Improper operation and self-performed removal or installation (only permitted by authorised specialist workshops) can cause loss of function and thus endangering of the passengers.
➤ Do not run the seat belt over hard or fragile objects in the pockets and clothing.
➤ Putting on the safety belt during pregnancy: The webbingrunning over the pelvis must run as low as possible over the pelvis to avoid pressure on the abdomen.

Caution
➤ Do not place any loads on the belt buckle. This can cause damages and impair the function.
➤ Do not insert any objects into the belt buckle, as this may impair the function or lead to loss of function.



3.3. Child safety systems – ISOFIX & Top-Tether (optional)

The seat supports the following fixing types for child safety systems:
Three point safety belt, ISOFIX and Top-Tether.

Note:

When using a child safety system, please always follow the instructions for use, installation and operation provided by the respective manufacturer.

Always make sure that local and national regulations are followed. In some countries, the use of child safety systems is prohibited on certain seats.

3.3.1. ISOFIX attachment

The ISOFIX connection consists of two retaining brackets with a thickness of 6 mm, which are located in the gap between the backrest and the seating surface.

The fastening system attached to the child seat is hooked into the retaining brackets (see pictures).

For details on fastening, please refer to the instruction manual of the child seat manufacturer.

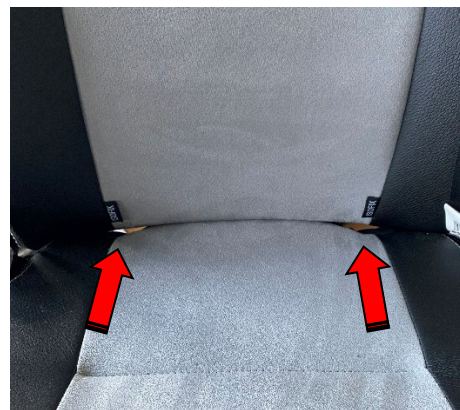
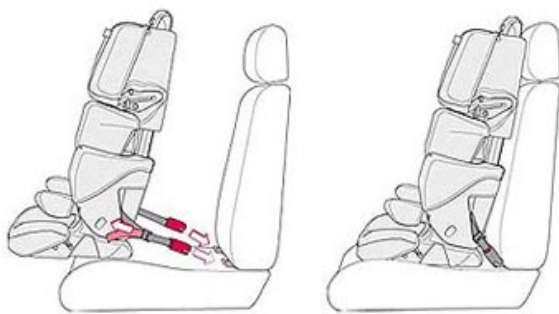

Caution

- Additional to the ISOFIX attachments, always use either a top tether strap or a support leg.

3.3.2. Top-Tether attachment



Top-Tether:

This is an additional strap, which is run over the backrest and attached to a bracket on the seat with a hook and then tensioned.



Caution: Please follow the exact instructions of the respective child seat manufacturer.

3.4. Arm rests (optional)

Caution

- Only use arm rests as such and never use them as a shelf or seat aid!

Arm rests can be folded upwards if required.



⚠ Warning: risk of crushing

- Do not touch the screw-on point of the arm rests while folding the arm rests.
- Only operate the arm rests, when crushing of others is not possible.

3.5. Adjustment of the backrest (optional)

⚠ Danger

- **Risk of accident: Do not adjust the seats while driving!** They could move uncontrollably and thereby endanger or injure fellow passengers and yourself.

⚠ Warning

- Do not stow any objects under the seats.
- Caution when operating the backrest adjustment, there is a risk of injury, especially for children. Make passengers aware that you are adjusting the seats.
- Make sure that the pivot range is always free when tilting the backrest to avoid collisions with people and objects.

⚠ Warning: risk of crushing

- Only adjust the seat using the adjustment levers provided for this purpose.
- Only operate the backrest adjustment lever fully concentrated. Never reach into the adjustment range or under the seat when adjusting the seat.



- Only operate the adjustment lever when crushing others is not possible.



Adjusting the backrest:

The backrest can be continuously adjusted into the desired position by operating (pushing down) the backrest adjustment lever.

Caution: Backrest is under tension and can snap forward!

4. Product information and dimensions

4.1. Product description

- Rigid back (HF) or adjustable backrest (RV)
- Integrated headrest
- Fully protected 3-point belt
- TÜV tested M1 and TÜV tested installation variants

4.2. Variants/versions/options

Scope of delivery according to selected and ordered variant (see order/delivery note).

- ISOFIX with Top-Tether
- Armrests Hostess
- 4-point belt
- Various accessories: handle, luggage net, folding table
- Safety belt warning system
- Special fabrics at extra charge

4.3. Scope of application

Passenger compartment in minibuses and vans.



4.4. Dimensions

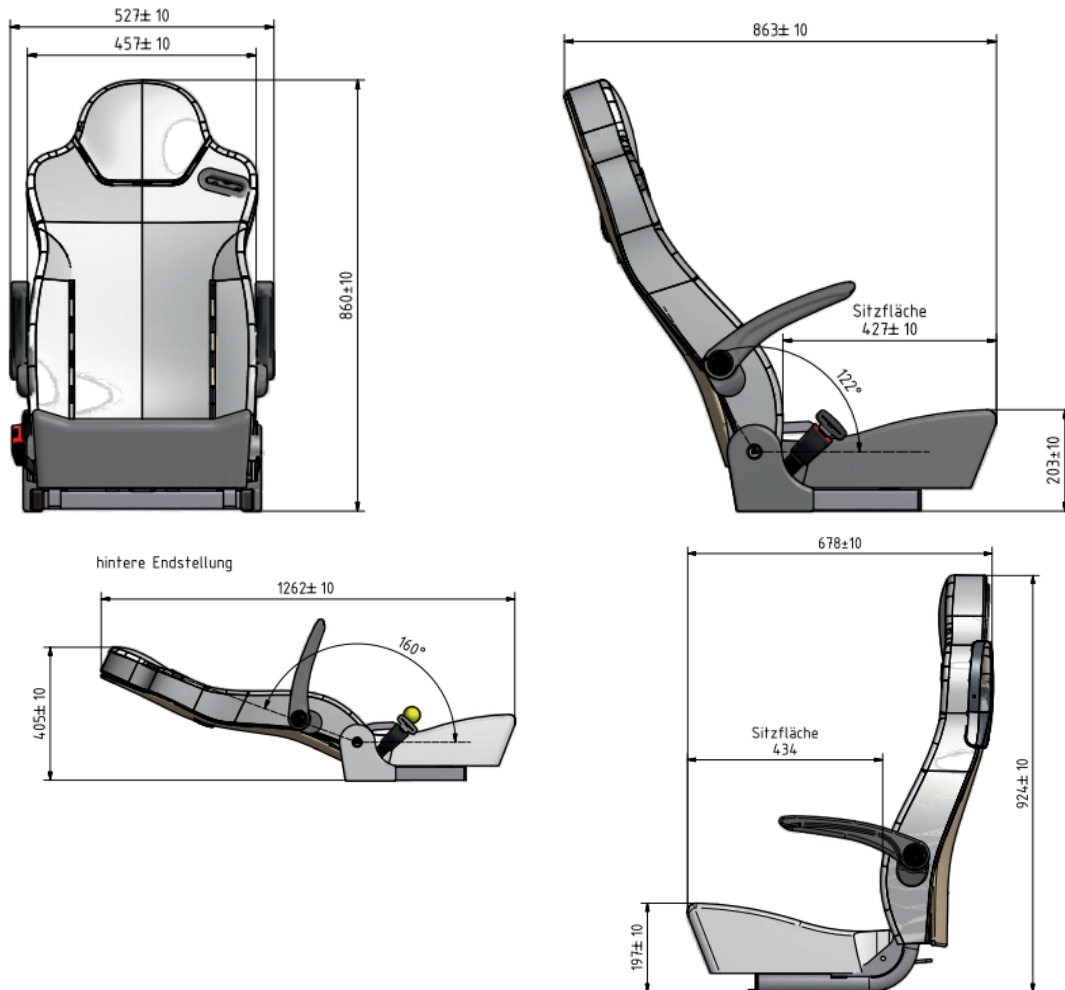

4.5. Load limits

Do not load the seat with more than 150 kg!



Warning

- Overloading could damage your seat and possibly cause safety defects.

5. Notes on disposal

- In general it is possible to dispose your seat through your vendor.
- When disposing yourself, please follow the disposal regulations of your country, these may differ from table below.
- Care must be taken to ensure that the waste is disposed of properly and in an environmentally friendly manner.

Disposal packaging	Cardboard, wood (e.g. pallet), foils	Disposal as cardboard (paper waste)/wood waste/foil waste
Disposal individual components	Cover	Disposal as residual waste
	Plastic parts and upholstery	Disposal as plastic waste (according to labelling and type of plastic)



	Metal components	Disposal as scrap iron
	Belt straps	Disposal as plastic waste – Polyester
	Buckle & tongue	Disposal as residual waste

Imprint:

Hermann Schnierle GmbH
Dieselstrasse 43
86368 Gersthofen

Tel: +49 821 299 930
E-Mail: info@schnierle.de
www.schnierle.de

Managing Director: Martin Schnierle, HRB Augsburg 7256

The information contained in this publication corresponds to the status stated below. Hermann Schnierle GmbH reserves the right to make changes to the technology, equipment and form of our products compared to the information in this publication as well as changes to this publication itself.